

M-Length Nylon Cable Glands



颜色定制 Color Customization 可为客户特殊定制其他颜色

白色RAL9003
 灰色RAL7035
 银灰RAL7001
 黑色RAL9005
 蓝色RAL5012
 红色RAL3020
 绿色RAL6032
 黄色RAL1026

M加长型电缆固定头		M-Length Nylon Cable Glands	
材料:	采用UL认可的尼龙材料	Material:	PA(NYLON),UL 94 V-2
防水圈:	丁晴橡胶, 耐候橡胶	Hermetic seal:	NBR,EPDM
O型圈:	耐候橡胶	O-Ring:	EPDM
工作温度:	静态-40°C至100°C或瞬间可耐热至120°C 动态-20°C至 80°C或瞬间可耐热至100°C	Working temperature:	-40°C to 100°C in static state instantaneous heat resistance up to 120°C -20°C to 80°C in static state instantaneous heat resistance up to 100°C
颜色种类:	灰色、黑色, 其他颜色可定做		

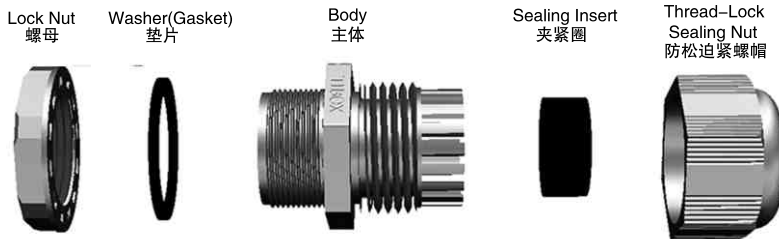
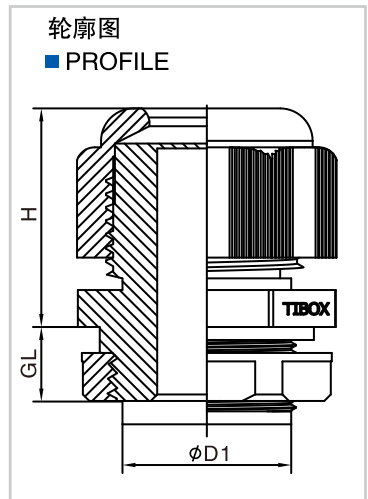

螺纹规格 Thread ØD1	适用电缆 mm	螺纹外径 AG mm	螺纹长度 GL mm	本体高度 H mm	扳手直径 mm	开孔尺寸 PanelMounting Hole mm	订货号 PartNO		包装 Std.Pkg. pcs
							灰色 Grey	黑色 Black	
M12 x 1.5	3 - 6.5	12	15	21	18	12 - 12.3	M1207L	M1207BL	50
M12 x 1.5	2 - 5	12	15	21	18	12 - 12.3	M1205L	M1205BL	50
M16 x 1.5	4 - 8	16	15	22	22	16 - 16.3	M1608L	M1608BL	50
M16 x 1.5	2 - 6	16	15	22	22	16 - 16.3	M1606L	M1606BL	50
M20 x 1.5	6 - 12	20	15	27	27	20 - 20.3	M2012L	M2012BL	50
M20 x 1.5	5 - 9	20	15	27	27	20 - 20.3	M2009L	M2009BL	50
M25 x 1.5	13 - 18	25	15	31	27	25 - 25.3	M2518L	M2518BL	50
M25 x 1.5	9 - 16	25	15	31	27	32 - 32.3	M2516L	M2516BL	50
M32 x 1.5	18 - 25	32	16	39	41	32 - 32.3	M3225L	M3225BL	10
M32 x 1.5	13 - 20	32	16	39	41	32 - 32.3	M3220L	M3220BL	10
M40 x 1.5	22 - 32	40	18	48	50	40 - 40.3	M4032L	M4032BL	10
M40 x 1.5	20 - 26	40	18	48	50	40 - 40.3	M4026L	M4026BL	10
M50 x 1.5	32 - 38	50	18	49	62	50 - 50.3	M5038L	M5038BL	10
M50 x 1.5	25 - 31	50	18	49	62	50 - 50.3	M5031L	M5031BL	10
M63 x 1.5	37 - 44	63	19	49	75	63 - 63.3	M6344L	M6344BL	10
M63 x 1.5	29 - 35	63	19	49	75	63 - 63.3	M6335L	M6335BL	10